

## CAT40 & Straight Shank ER25 Collet Chucks

(Balanced to G2.5@18,000 RPM)

- Small diameter nose well-suited for working in close quarters
- Increased flexibility for milling, drilling, and reaming
- Flush precision collet nut, grips tool close to cutting edge for accuracy and rigidity
- Concentric to .0002" TIR puts tool precisely on spindle center line
- AT3 or better shank taper allows for accurate, rigid toolholder-to-spindle mount
- Wide range collets reduce collet and toolholder inventories
- Fully ground flange and V-groove is easy on tool changers for less spindle and changer maintenance
- Through spindle coolant standard
- **ER25 Collets found on pages 606-607.**

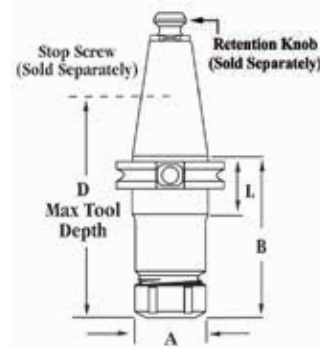

### CAT40 ER25 Collet Chucks

Capacity	Taper	A	Gage Length (B)	D	L	Max. Nosepiece Torque	Part #
.040-.629	CAT40	1.64	2.50	3.00	1.38	42 ft lbs	<a href="#">RC4ER25250</a>
.040-.629	CAT40	1.64	4.00	3.50	1.38	42 ft lbs	<a href="#">RC4ER25400</a>
.040-.629	CAT40	1.64	6.00	3.50	1.38	42 ft lbs	<a href="#">RC4ER25600</a>

### ER25 Straight Shank Collet Extension

A	B	D	L	Photo	Dimensions	Part #
1.64	7.5	1.00	5.5			<a href="#">RSSER25750</a>

### ER25 Parts & Accessories

Description	Photo	Dimensions	Part #
ER25 Replacement Nosepiece			<a href="#">RER25NPA</a>
ER25 Collet Wrench†			<a href="#">RER25W</a>
ER25 Stop Screw			<a href="#">RER25SS</a>
ER25 Stop Screw Coolant Thru			<a href="#">RER25SSC</a>

†Required for assembly.